

Ordering code

CCD	NPO	103	M	2K	10	0	7	1	B
1	2	3	4	5	6	7	8	9	10

1.Type

TYPE	CCD: Ceramic capacitor	CCE: Epoxy coating
------	------------------------	--------------------

2.Temperature Characteristic

Code	NPO (CH)	SL
TEMP. COEFF. (PPM/°C)	0±60	+350~-1000

Code	B	E	F
CAP. Change (%)	±10	+22,-56	+22,-82

3.Rated Capacitance

Code	PF	Code	PF
005	5P	222	2200P
010	10P	103	10000P
221	220P	104	100000P

4.Capacitance Tolerance

Code	CAP. TOL.	Code	CAP. TOL.
B	±0.1PF	J	±5%
C	±0.25PF	K	±10%
D	±0.5PF	M	±20%
F	±1%	Z	+80-20%
G	±2%	P	+100-0%

5.Rated Voltage

Code	CAP. TOL.	Code	CAP. TOL.
1C	16V	2H	500V
1E	25V	1K	1000V
1H	50V	2K	2000V
2A	100V	3K	3000V
2B	250V	6K	6000V

6.Size Code

Code	DIA(mm)
05	5
10	10
12	12

7.Pitch

Code	Pitch (mm)	Code	Pitch (mm)
2	2.5±0.8	7	7.52±0.8
5	5±0.8	0	9.5±0.8
6	6.35±0.8		

8.Lead Length

Code	Lead length (mm)	Code	Lead length(mm)
3	3±0.8	0	10±0.8
5	5±0.8	1	25±3
7	7±0.8		

9.Lead Style

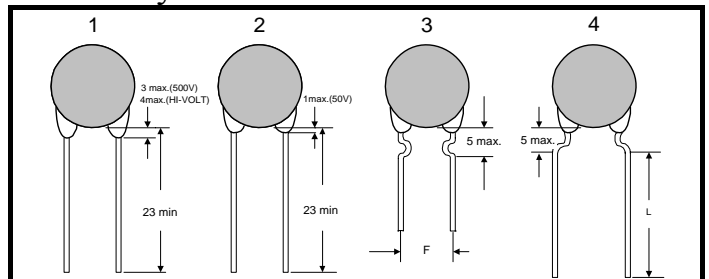

10.Packing

Code	Type
A	Ammo Pack Taping
R	Reel Pack Taping
B	BULK

50/100V Series

W.V. (DC)	TEMP.Char./Capacitance range(PF)					DIA (mm)
	NPO (CH)	SL	B (Y5E)(Y5P)	E (Z5U)	F (Z5V)	
50V/100V	0.5~47	33~150	100~2200	1000~5000	3300~10000	5±1
	47~68	180~220	3300	5600~6800		6±1
	75~100	250~330	3900	7500~10000	12000~22000	7±1
	120~150	390	4700~6800			8±1
	180~200	470~560				9±1
	220~270	680~820	7500~10000	20000~22000		10±1
	300~330					12±1
	470					14±1

### 500V Series

W.V. (DC)	TEMP.Char./Capacitance range(PF)					DIA (mm)
	NPO (CH)	SL	B (Y5E)(Y5P)	E (Z5U)	F (Z5V)	
500V	0.5~50	10~68	100~680	1000~2200	2000~2200	5±1
	47~56	82~100	820~1200	2200~3300	2200~4700	6±1
	65~82	120~150	1500~1800	3900~5000	5000~6800	7±1
	91~100	180~220	2000~2700	5600~6800	8200~10000	8±1
	100~120	390~470	3000~3300	8200~10000		9±1
	150~180	680~820	3900~5200			10±1
	200~220		5600~6800	12000~15000	15000~22000	12±1
		900~1000	8200~10000	18000~22000	27000~47000	14±1
				100000	16±1	

### Semi-Conductive Series

W.V. (DC)	TEMP.Char./Capacitance range(PF)			DIA (mm)
	B (Y5P)	E (Y5U)	F (Y5V)	
12V/16V		100000	100000	6±1
			220000	8±1
25V	10000	1000	10000~22000	3.5±1
	22000	47000		5±1
	33000		100000	6±1
	47000			6.5±1
	68000	100000		7±1
	100000			8±1
50V/100V		10000	10000~22000	3.5±1
	10000	22000	47000	4.5±1
	15000	33000~47000		5±1
	22000		100000	6±1
	33000~47000	100000		8±1
		220000		10±1
	100000			12.5±1

### Taping Dimensions

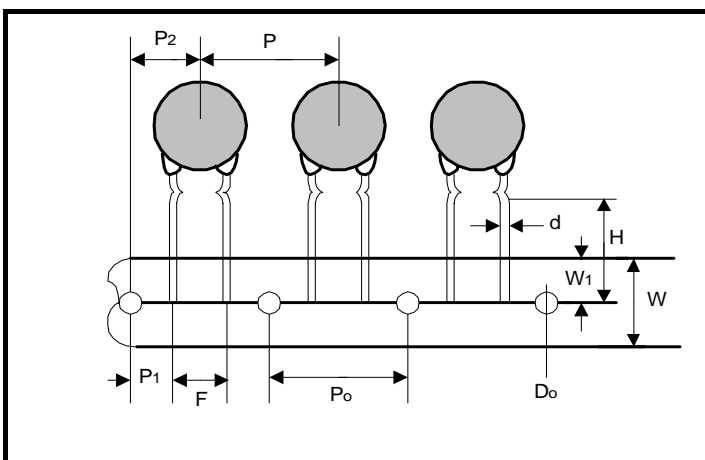
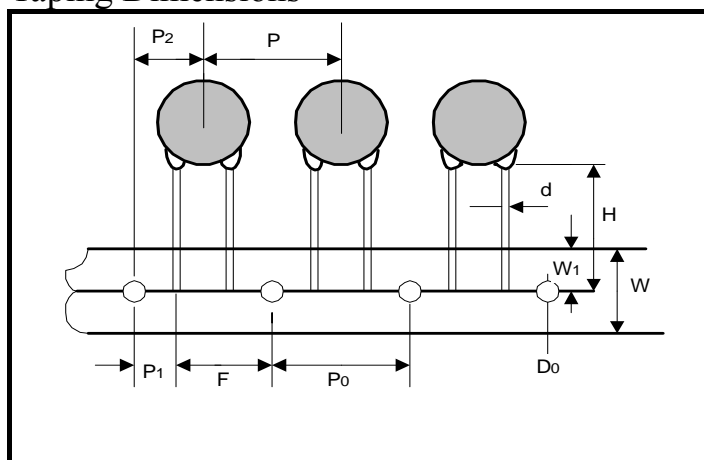

### Formed Leads and Taping

Units : mm(inch)

Symbol	Dimensions	Remarks
P	12.7±1(0.500±0.039)	Less than 2 mm of cumulative error per 20 pitches
P <sub>0</sub>	12.7±0.3(0.500±0.012)	
P <sub>1</sub>	3.85±0.5(0.152±0.020)	
P <sub>2</sub>	6.35±1(0.250±0.039)	

F	5±0.8(0.197±0.031)	
W	18±0.5(0.709-0.020)	
W <sub>1</sub>	9±0.5(0.354-0.020)	
H	20+1.5-1.0(0.787+0.059-0.039)	
ØD <sub>0</sub>	4±2(0.157±0.008)	
Ød	0.6+0.06-0.05(0.024+0.002-0.002)	

### AMMO-PACK

### REEL-PACK

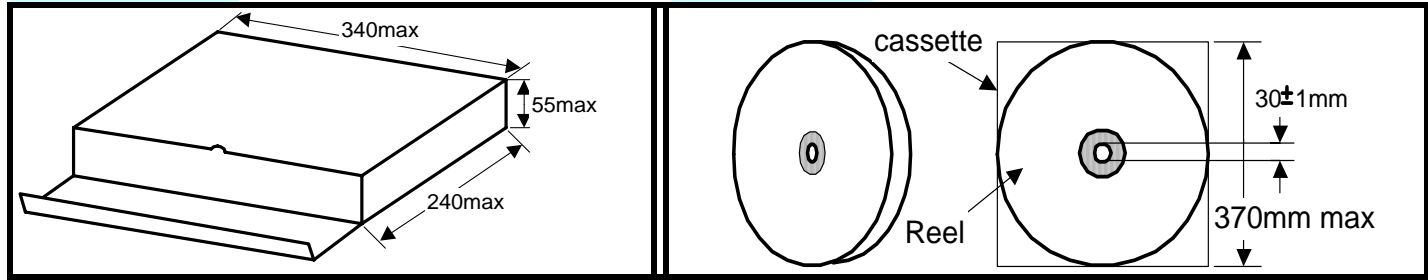

### RELIABILITY DATA

No	ITEM	CLASS I	CLASS II	CLASS III	Measuring Condition															
1	Operating Temperature Range	-25°C~+85°C	B: -25°C~+85°C E&F: -25°C~+85°C	F: -25°C~+85°C (Y5V)																
2	Temperature Characteristics	CH: 0±60ppm/°C SL: +350-1000ppm/°C	B: ±10% E: +22%-56% F: +22%-82%	+22% -82%	<p>Retain the sample for 30 minutes at the temperature specified below in the sequence listed in the table. Then measure the capacitance in each step after thermal equilibrium at each temperature is reached.</p> <table border="1"> <thead> <tr> <th>Step1</th> <th>Step2</th> <th>Step3</th> <th>Step4</th> <th>Step5</th> </tr> </thead> <tbody> <tr> <td>Room Temp</td> <td>Operating Temp(min)</td> <td>Room Temp</td> <td>Operating Temp(min)</td> <td>Room Temp</td> </tr> <tr> <td>25±2°C</td> <td>-25±3°C +10±2°C</td> <td>25±2°C</td> <td>85±2°C</td> <td>25±2°C</td> </tr> </tbody> </table> <p>Note that step 1 and 2 do not apply for the SL characteristics.</p>	Step1	Step2	Step3	Step4	Step5	Room Temp	Operating Temp(min)	Room Temp	Operating Temp(min)	Room Temp	25±2°C	-25±3°C +10±2°C	25±2°C	85±2°C	25±2°C
Step1	Step2	Step3	Step4	Step5																
Room Temp	Operating Temp(min)	Room Temp	Operating Temp(min)	Room Temp																
25±2°C	-25±3°C +10±2°C	25±2°C	85±2°C	25±2°C																
3	Capacitance	Within the specified tolerance			Shall be measured 25±2°C normal temperature at the frequency and voltage															
4	Q or Dissipation Factor (tan δ)	C≥30pF; Q≥1000 C<30pF; Q≥400+20·c (C is nominal capacitance)	B&E: tan δ≤0.025 F: tan δ≤0.05	F: tan δ≤0.05	<p>Class I: 1MHz±20%, 1±0.2Vrms Class II: 1KHz±10%, 1±0.2Vrms Class III: 1KHz±20%, 0.5±0.05Vrms</p>															
5	Withstanding Voltage	No defects			<p>Applied: Rated voltage·3 (class I) Rated voltage·2.5 (class II) Rated voltage·2 (class III)</p> <p>Duration: 1 to 5 sec. The charge/discharge current is less than 50mA.</p>															
6	Insulation Resistance	More than 10GΩ	More than 10GΩ or 200Ω·F, whichever is less	More than 1GΩ or 20Ω·F, whichever is less	<p>Apply rated voltage for 1 minute at 25±2°C and 70% R.H. max. 16Vdc product: Measurement voltage is 25Vdc</p>															
7	Pull Test (Tensile stress)	Termination not to be broken or loosened			<p>Fix the capacitor, apply the tensile stress listed below in the terminal extraction direction until the designated value is reached. Then retain the capacitor for 10±0.1 seconds as is.</p> <table border="1"> <thead> <tr> <th>Nominal wire diameter</th> <th>0.5 mm</th> <th>0.6 mm</th> </tr> </thead> <tbody> <tr> <td>Tensile stress</td> <td>5N</td> <td>10N</td> </tr> </tbody> </table>	Nominal wire diameter	0.5 mm	0.6 mm	Tensile stress	5N	10N									
Nominal wire diameter	0.5 mm	0.6 mm																		
Tensile stress	5N	10N																		
8	Solderability of Leads	At least three-fourths of the immersed surface in the circumference direction is covered with new solder.			<p>Solder temperature: 230±5°C Dipping: 3±0.5 sec. (Flux shall be used)</p>															
9	Resistance to Solder Heat	ΔC	±2.5% or ±0.25pF (Whichever is greater)	B: ±5% E: ±15% F: ±20%	F: ±30% (Y5V)															
		Withstanding voltage	No defects																	
		Exterior	No abnormalities																	
		ΔC	±2.5% or ±0.25pF (Whichever is greater)	B: ±5% E: ±15% F: ±20%	F: ±30% (Y5V)															

	CLASS I, II	CLASS III
Solder temperature	350±10°C	260±5°C
Duration	3±0.5sec	5±0.5sec

The measurements after testing must be taken after leaving the sample for 12 to 24 hours under normal temperature and humidity conditions.

Fix the capacitor to the supporting jig in the same manner and under the same conditions as (10). Perform the five cycles according to the four heat

10	Thermal shock	Q/D.F.	C $\geq$ 30pF: Q $\geq$ 1000 C<30pF: Q $\geq$ 400+20 $\cdot$ C C is nominal capacitance	B&E: tan $\delta \leq 0.025$ F : tan $\delta \leq 0.05$	F : tan $\delta \leq 0.05$ (Y5V)	treatments listed in the following table. <table border="1"> <tr> <th>Step 1</th> <th>Step 2</th> <th>Step 3</th> <th>Step 4</th> </tr> <tr> <td>Operating Temp(min)</td> <td>Room Temp</td> <td>Operating Temp(max)</td> <td>Room Temp</td> </tr> <tr> <td>30<math>\pm</math>3</td> <td>15</td> <td>30<math>\pm</math>3</td> <td>15</td> </tr> </table> <p>The measurements after testing must be taken after leaving the sample for 12 to 24 hours under normal temperature and humidity conditions.</p>	Step 1	Step 2	Step 3	Step 4	Operating Temp(min)	Room Temp	Operating Temp(max)	Room Temp	30 $\pm$ 3	15	30 $\pm$ 3	15
		Step 1	Step 2	Step 3	Step 4													
		Operating Temp(min)	Room Temp	Operating Temp(max)	Room Temp													
		30 $\pm$ 3	15	30 $\pm$ 3	15													
I.R.	More than 10G $\Omega$	More than 10G $\Omega$ or 20 $\Omega$ ·F, whichever is less	More than 10G $\Omega$ or 20 $\Omega$ ·F, whichever is less															
Withstanding voltage	No defects																	
Exterior	No abnormalities																	
11	Moisture resistance (steady state)	$\Delta$ C	$\pm 5\%$ or $\pm 0.5$ pF (Whichever is greater)	B : $\pm 10\%$ E : $\pm 20\%$ F : $\pm 30\%$	F : $\pm 30\%$ (Y5V)	Temperature: 40 $\pm 2^\circ$ C Humidity 90 to 95% R.H. Duration: 500+24-0 Hrs.  The measurements after testing must be taken after leaving the sample for 1 to 2 hours under normal temperature and humidity conditions. *Perform a heat treatment at 40 $\pm 2^\circ$ C for 1 hours. Remove and let sit for 1 to 2 hours at normal temperature and humidity conditions. Perform the initial measurement												
		Q/D.F.	C $\geq$ 30pF: Q $\geq$ 350 10pF<C<30pF: Q $\geq$ 275+5/2 $\cdot$ C C $\leq$ 10pF: Q $\geq$ 200+10 $\cdot$ C	B&E: tan $\delta \leq 0.05$ F : tan $\delta \leq 0.075$	F : tan $\delta \leq 0.075$ (Y5V)													
		I.R.	More than 1G $\Omega$	More than 1G $\Omega$ or 20 $\Omega$ ·F, whichever is less	More than 500M $\Omega$ or 10 $\Omega$ ·F, whichever is less													
		Withstanding voltage	No defects															
		Exterior	No abnormalities															
12	High Temperature loading	$\Delta$ C	$\pm 5\%$ or $\pm 0.5$ pF (Whichever is greater)	B : $\pm 10\%$ E : $\pm 20\%$ F : $\pm 30\%$	F : $\pm 30\%$ (Y5V)	Applied Voltage: Rated voltage $\cdot 2$ (CLASS I, II) Rated voltage $\cdot 1.25$ (CLASS III) Temperature: 85 $\pm 2^\circ$ C Duration: 1000+48-0 Hrs. The charge/discharge current is less than 10mA The measurements after testing must be taken after leaving the sample for 12 to 24 hours under normal temperature and humidity conditions. *Perform a heat treatment at 85 $\pm 2^\circ$ C for 1 hours. Remove and let sit for 12 to 24 hours at normal temperature and humidity conditions. Perform the initial measurement												
		Q/D.F.	C $\geq$ 30pF: Q $\geq$ 350 10pF<C<30pF: Q $\geq$ 275+5/2 $\cdot$ C C $\leq$ 10pF: Q $\geq$ 200+10 $\cdot$ C	B&E: tan $\delta \leq 0.05$ F : tan $\delta \leq 0.075$	F : tan $\delta \leq 0.075$ (Y5V)													
		I.R.	More than 1G $\Omega$	More than 1G $\Omega$ or 20 $\Omega$ ·F, whichever is less	More than 500M $\Omega$ or 10 $\Omega$ ·F, whichever is less													
		Withstanding voltage	No defects															
		Exterior	No abnormalities															

### 1KV Series

W.V. (DC)	TEMP.Char./Capacitance range(PF)					DIA (mm)
	NPO (CH)	SL	B (Y5E)(Y5P)	E (Z5U)	F (Z5V)	
1KV	1~10	30~56	100~470	1000~1200		5 $\pm$ 1
	12~33	68~100	500~1000	1500~2200		6 $\pm$ 1
	39~50	120~150		2700~3300	4700	7 $\pm$ 1
	56~68	180~220	1500~1800	3900~10000	5000~10000	8 $\pm$ 1
	79~90	270~330	2000~2200	8200~10000		9 $\pm$ 1
	100~120	350~390	2700~3300		22000	10 $\pm$ 1
					22000	11 $\pm$ 1
	150~180	470~560	3900~4700	12000		12 $\pm$ 1
	200~220	680~820	5000~6800	22000		14 $\pm$ 1
				47000	20 $\pm$ 1	

### 2KV Series(Epoxy Coating)

W.V. (DC)	TEMP.Char./Capacitance range(PF)					DIA (mm)
	NPO (CH)	SL	B (Y5E)(Y5P)	E (Z5U)	F (Z5V)	
2KV	1~20	15~56	100~470	1000~1200		5 $\pm$ 1
	22~30	68~100	560~1000	1500~2200	3300~3900	6 $\pm$ 1
	33~39	120~150	1200	2700~3300	4700~5000	7 $\pm$ 1
	47~50	180	1500	3500~3900	5600~6800	8 $\pm$ 1
	56~68	200~220	1800~2200	4700~6800	8200	9 $\pm$ 1
	75~82	270~300	2700	8200~10000	10000	10 $\pm$ 1
	90~100	330	3000~3300		12000	11 $\pm$ 1
	110~120					12 $\pm$ 1
	150	390	3900			13 $\pm$ 1

			4700~5600			14±1
--	--	--	-----------	--	--	------

### 3KV Series(Epoxy Coating)

W.V. (DC)	TEMP.Char./Capacitance range(PF)					DIA (mm)
	NPO (CH)	SL	B (Y5E)(Y5P)	E (Z5U)	F (Z5V)	
3KV	1~18	15~47	100~470	1000~1200	1800~2200	6±1
	20~30	50~68	680~820	1500	2700~3300	7±1
	33~39	82~100	1000	1800~2000	3900	8±1
	47~56	120	1200	2200~2700	4700~5600	9±1
	62~68	150~180	1500	3000~6800	6800	10±1
	75~82	200~220	1800		8200	11±1
	90~100	270	2000~2200		10000	12±1
	110~120	300~330				13±1
	150		2700~3300	10000		14±1

### 6KV,10KV Series(Epoxy Coating)

W.V. (DC)	TEMP.Char./Capacitance range(PF)			DIA (mm)
	SL	B (Y5E)(Y5P)	E (Z5U)	
6KV	5~22	100~330	1000	6±1.5
	27~39	390~500		7±1.5
	47~68	560~680	1500~2200	8±1.5
	82	820		9±1.5
	100~120	1000	3300	10±1.5
	150			11±1.5
			1500	12±1.5
				13±1.5
			14±1.5	
			15±1.5	
10KV		100~120		7±1.5
		150~180		7±1.5
		200~220		7±1.5
		270~330		8±1.5
		470~560		10±1.5
		680		12±1.5

Temperature Dependency of Capacitance (Approx. Values)

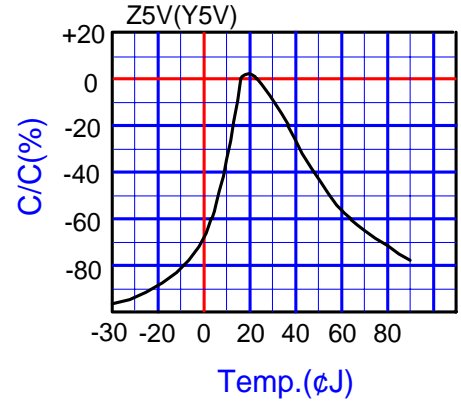
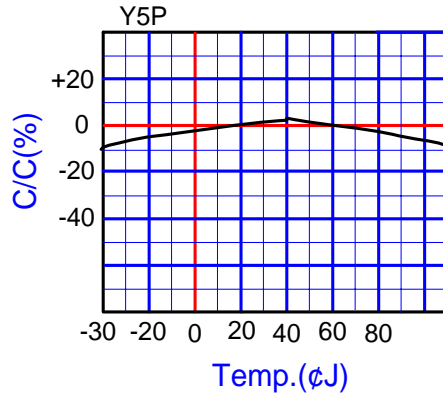
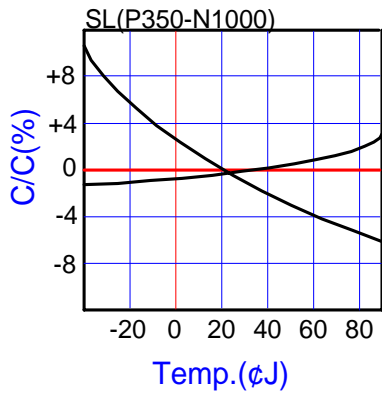
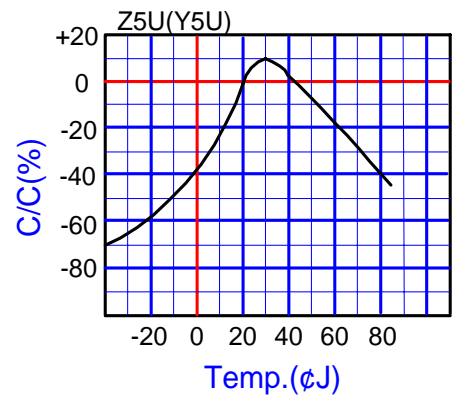
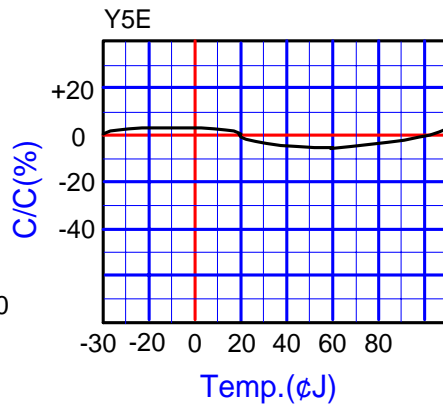
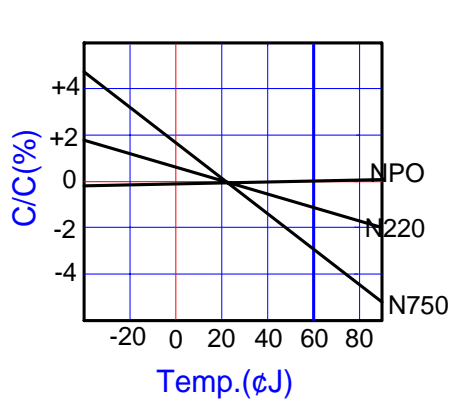

## Medium-High Voltage Capacitors

No	ITEM	CLASS I	CLASS II	Measuring Condition															
1	Operating Temperature Range	-25°C~+85°C	B:-25°C~+85°C E&F:-25°C~+85°C																
2	Temperature Characteristics	CH:0±60ppm/°C SL:+350-1000ppm/°C	B: ±10% E:+22%~56% F:+30%~82%	Retain the sample for 30 minutes at the temperature specified below in the sequence listed in the table. Then measure the capacitance in each step after thermal equilibrium at each temperature is reached. <table border="1"> <thead> <tr> <th>Step1</th> <th>Step2</th> <th>Step3</th> <th>Step4</th> <th>Step5</th> </tr> </thead> <tbody> <tr> <td>Room Temp</td> <td>Operating Temp(min)</td> <td>Room Temp</td> <td>Operating Temp(min)</td> <td>Room Temp</td> </tr> <tr> <td>25±2°C</td> <td>-25±3°C +10±2°C</td> <td>25±2°C</td> <td>85±2°C</td> <td>25±2°C</td> </tr> </tbody> </table> Note that step 1 and 2 do not apply for the SL characteristics.	Step1	Step2	Step3	Step4	Step5	Room Temp	Operating Temp(min)	Room Temp	Operating Temp(min)	Room Temp	25±2°C	-25±3°C +10±2°C	25±2°C	85±2°C	25±2°C
Step1	Step2	Step3	Step4	Step5															
Room Temp	Operating Temp(min)	Room Temp	Operating Temp(min)	Room Temp															
25±2°C	-25±3°C +10±2°C	25±2°C	85±2°C	25±2°C															
3	Capacitance	Within the specified tolerance		Shall be measured 25±2°C normal temperature at the frequency and voltage															
4	Q or Dissipation Factor (tan δ)	C≥30pF; Q≥1000 C<30pF; Q≥400+20·C (C is nominal capacitance)	B&E: tan δ≤0.025 F: tan δ≤0.05	Class I: 1MHz±20%, 1±0.2Vrms Class II: 1KHz±10%, 1±0.2Vrms															
5	Withstanding Voltage	Between Terminals	No defects	Applied: Rated voltage·2 (class I) Rated voltage·1.5 (class II) Duration: 60 sec. The charge/discharge current is less than 50mA.															
		Between Terminals and body	No defects	Applied voltage: 1.3KVDC Duration: 60 sec.															
6	Insulation Resistance	More than 10GΩ or 200Ω·F, whichever is less		Apply 500VDC for 1 minute at 25±2°C and 70% R.H. max.															
7	Strength of termination	Termination not to be broken or loosened		Fix the capacitor, apply the tensile stress listed below in the terminal extraction direction until the designated value is reached. Then retain the capacitor for 10±0.1 seconds as is. <table border="1"> <thead> <tr> <th>Nominal wire diameter</th> <th>0.6 mm</th> <th>0.7 mm</th> </tr> </thead> <tbody> <tr> <td>Tensile stress</td> <td>10N</td> <td>10N</td> </tr> </tbody> </table>	Nominal wire diameter	0.6 mm	0.7 mm	Tensile stress	10N	10N									
Nominal wire diameter	0.6 mm	0.7 mm																	
Tensile stress	10N	10N																	
8	Solderability of Leads	At least three-fourths of the immersed surface in the circumference direction is covered with new solder.		Solder temperature: 230±5°C Dipping: 3±0.5 sec. (Flux shall be used)															
	Resistance	±2.5% or ±0.25pF (Whichever is greater)	B: ±5% E: ±15% F: ±20%	The lead wire immersed in the melted solder 1.5mm to 2mm from the capacitor body. Solder temperature: 350±10°C															

9	to Solder Heat	Withstanding voltage	No defects		Dipping: 3±0.5 sec. The measurements after testing must be taken after leaving the sample for 12 to 24 hours under normal temperature and humidity conditions.												
		Exterior	No abnormalities														
10	Thermal shock	ΔC	±2.5% or ±0.25pF (Whichever is greater)	B : ±5% E : ±15% F : ±20%	Fix the capacitor to the supporting jig in the same manner and under the same conditions as(10). Perform the five cycles according to the four heat treatments listed in the following table. <table border="1" data-bbox="917 264 1401 389"> <tr> <th>Step 1</th> <th>Step 2</th> <th>Step 3</th> <th>Step 4</th> </tr> <tr> <td>Operating Temp(min)</td> <td>Room Temp.</td> <td>Operating Temp(max)</td> <td>Room Temp.</td> </tr> <tr> <td>30±3</td> <td>15</td> <td>30±3</td> <td>15</td> </tr> </table> The measurements after testing must be taken after leaving the sample for 12 to 24 hours under normal temperature and humidity conditions.	Step 1	Step 2	Step 3	Step 4	Operating Temp(min)	Room Temp.	Operating Temp(max)	Room Temp.	30±3	15	30±3	15
		Step 1	Step 2	Step 3		Step 4											
		Operating Temp(min)	Room Temp.	Operating Temp(max)		Room Temp.											
		30±3	15	30±3		15											
		Q/D.F.	C≥30pF: Q≥1000 C<30pF: Q≥400+20·C C is nominal capacitance	B&E:tan δ≤0.025 F : tan δ≤0.075													
I.R.	More than 1GΩ or 200Ω·F, whichever is less																
Withstanding voltage	No defects																
Exterior	No abnormalities																
11	Moisture resistance (steady state)	ΔC	±5% or ±0.5pF (Whichever is greater)	B : ±10% E : ±20% F : ±30%	Temperature: 40±2°C Humidity 90 to 95% R.H. Duration:500+24-0 Hrs.  The measurements after testing must be taken after leaving the sample for 1 to 2 hours under normal temperature and humidity conditions. *Perform a heat treatment at 40±2°C for 1 hours. Remove and let sit for 1 to 2 hours at normal temperature and humidity conditions. Perform the initial measurement												
		Q/D.F.	C≥30pF: Q≥350 10pF<C<30pF: Q≥275+5/2·C C≤10pF: Q≥200+10·C	B&E:tan δ≤0.05 F : tan δ≤0.075													
		I.R.	More than 1GΩ	More than 1GΩ or 20Ω·F (whichever is less)													
		Withstanding voltage	No defects														
		Exterior	No abnormalities														
12	High Temperature loading	ΔC	±5% or ±0.5pF (Whichever is greater)	B : ±10% E : ±20% F : ±30%	Applied Voltage : Rated voltage·1.5 Temperature: 85±2°C Duration:1000+48-0 Hrs.  The charge/discharge current is less than 10mA The measurements after testing must be taken after leaving the sample for 12 to 24 hours under normal temperature and humidity conditions. *Perform a heat treatment at 85±2°C for 1 hours. Remove and let sit for 12 to 24 hours at normal temperature and humidity conditions. Perform the initial measurement												
		Q/D.F.	C≥30pF: Q≥350 10pF<C<30pF: Q≥275+5/2·C C≤10pF: Q≥200+10·C	B&E:tan δ≤0.05 F : tan δ≤0.075													
		I.R.	More than 1GΩ	More than 1GΩ or 20Ω·F (whichever is less)													
		Withstanding voltage	No defects														
		Exterior	No abnormalities														

\*Note on standard condition : "standard condition" referred to herein is defined as follow:

5 to 35°C of temperature, 45 to 85% relative humidity, and 86 to 106kPa of air pressure.

\*When there are questions concerning measurement results:

in order to provide correlation data, the test shall be conducted under condition of 25°C±2°C of temperature, 60 to 70% relative humidity, and 86 to 106kPa of air pressure. Unless otherwise specified, all the tests are conducted under the "standard condition".